

axis
JAPAN

日本の品質
— JAPAN QUALITY —



APS401B
12/24V PARKING SENSOR SYSTEM

CONTENTS

General Installation Diagram.....	3
Error Codes.....	4
Dip Switch Setting.....	4
Brake Pedal Control.....	5
Reverse Parking Mode.....	5
Parking Distance Alarm.....	5
Sensor Installation Diagram.....	7
Advised Position to Install the Sensor.....	8
Drilling Position.....	9
Drilling.....	10
Sensor Installtion.....	10
Control Box Installtion.....	11
Trouble Shooting.....	12
Specifications.....	13
Notes.....	14, 15
Warranty.....	16

GENERAL INSTALLATION DIAGRAM

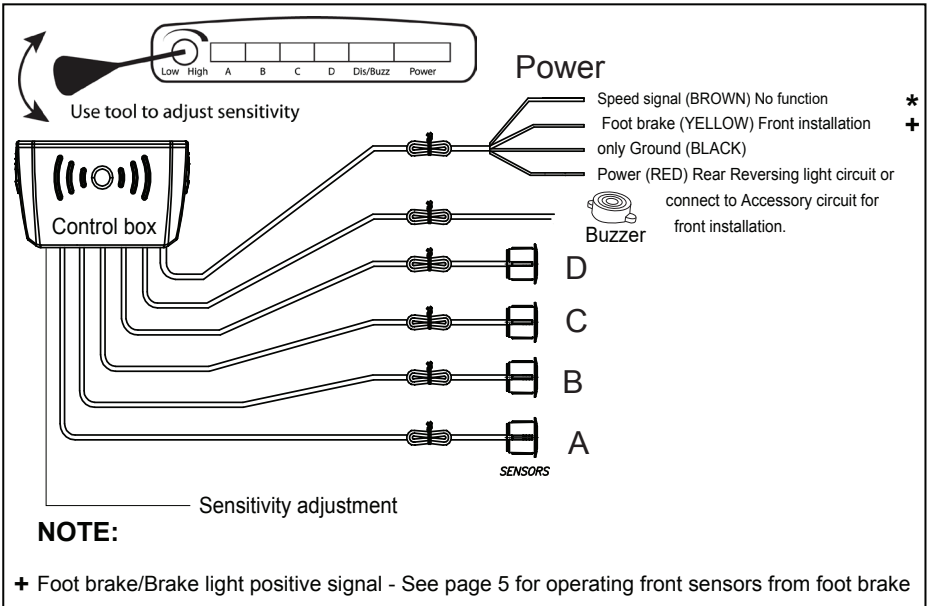
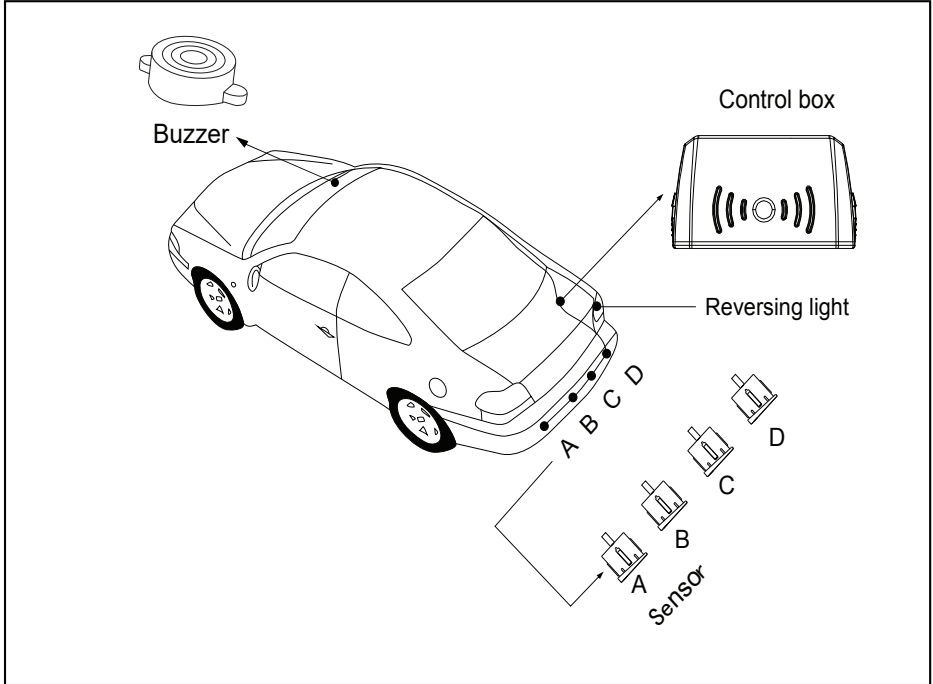

ERROR CODES

When the system turns on, each sensor is automatically tested. If the system cannot detect any of the sensors, the buzzer will beep to indicate which sensor is not detected. If a sensor is not detected, check the connections between the sensor and the module.

Beep	Definition
One beep	Sensor A not detected
Two beeps	Sensor B not detected
Three beeps	Sensor C not detected
Four beeps	Sensor D not detected

DIP SWITCH SETTING

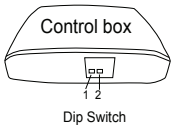

DIP 1	Function			
	Front and rear mode selection			
	UP	ON	Front installation	0.3~0.9m
	DOWN	OFF	Rear installation	0.3~2.5m

DIP 2 (Front Installation)	Detection Range Adjustment for Front Installation		
	UP	ON	0.5m
	DOWN	OFF	0.9m

DIP 2 (Rear Installation)	Tow Bar Adjustment		
	UP	ON	Objects within 20cm (e.g. tow-bar) will not be detected.
	DOWN	OFF	Objects within 20cm will be detected.

BRAKE PEDAL CONTROL (front installation only)

When the brake pedal is pressed, the front parking sensors will activate, when the brake pedal is released, the front parking sensors will remain active for 15 seconds, if no obstacle is detected within 15 seconds, the front parking sensors will deactivate; if an obstacle is detected within 15 seconds, the system will remain active for another 15 seconds.

REVERSE PARKING MODE

While the vehicle is in reverse, the rear parking sensors will be activated. While the vehicle is not in reverse, the rear parking sensors will be deactivated.

PARKING DISTANCE ALARM

Sound alarm
Silent
Bi.....Bi.....Bi.....
Bi..Bi..Bi..
Bi.....

SENSOR INSTALLATION DIAGRAM

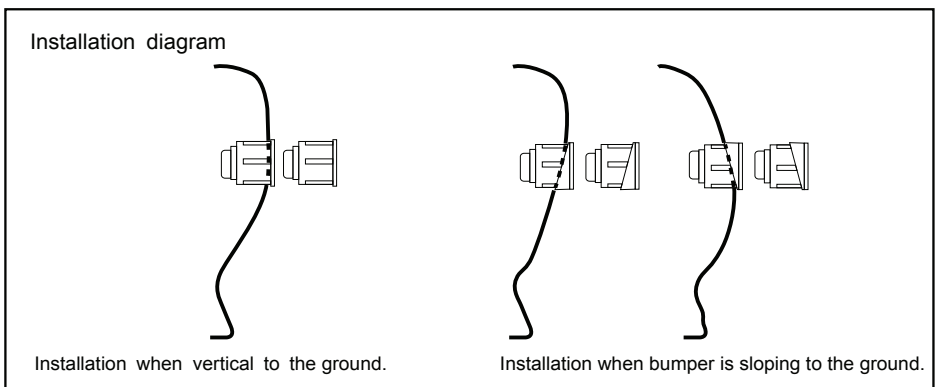
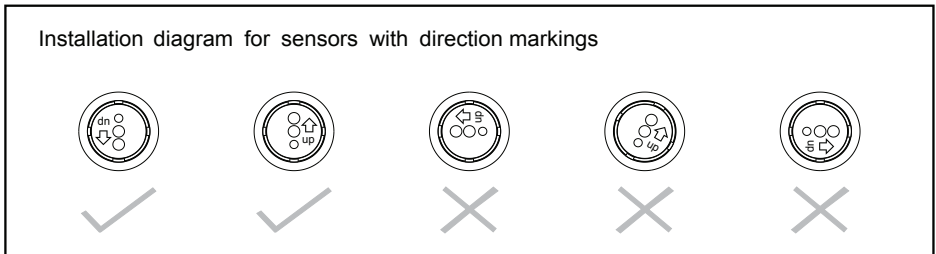
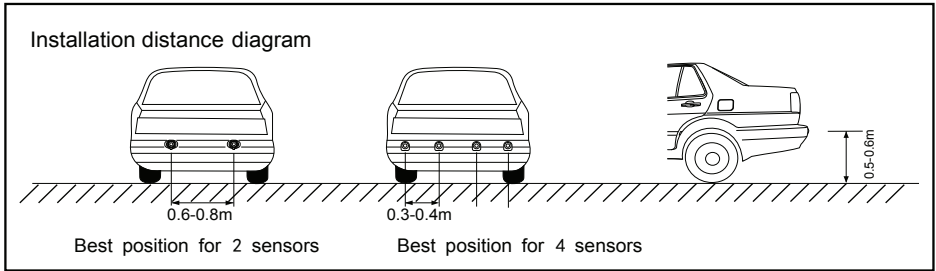
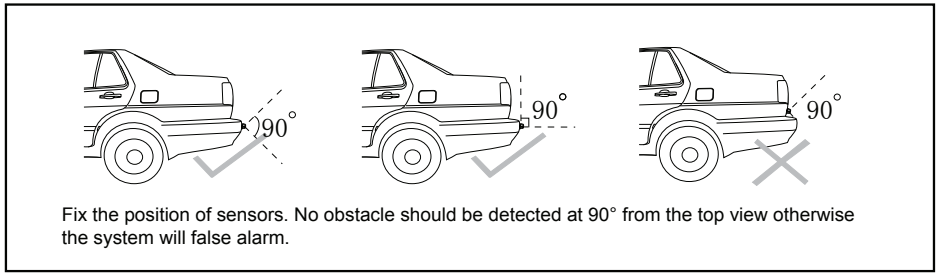

Smooth slope

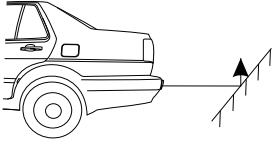

Smooth round objects

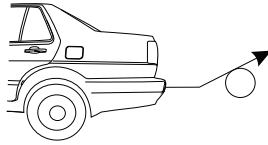

Objects absorbing wave, e.g. cotton

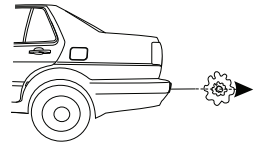

Objects hard to be detected (eg: clothing)

ADVISED POSITION TO INSTALL THE SENSOR

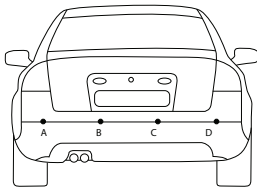

A. Four drill holes A.B.C.D should be in line.

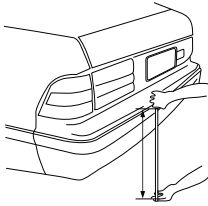

B. 0.5-0.6m vertical to the ground.
0.55m is recommended.

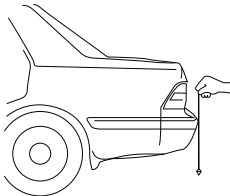

C. Vertical, tidy surface without
metal components is preferred.

SELECT DRILLING POSITION FOR SENSOR A & D

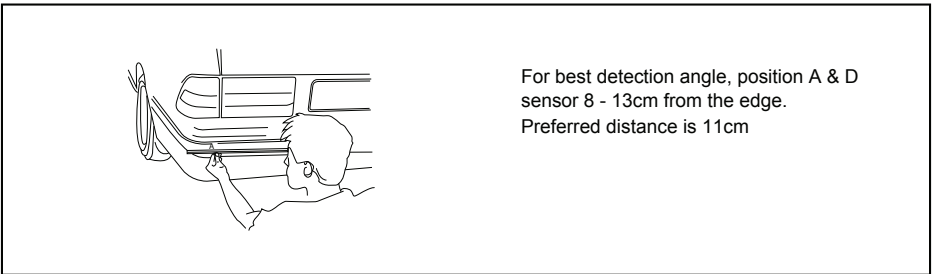
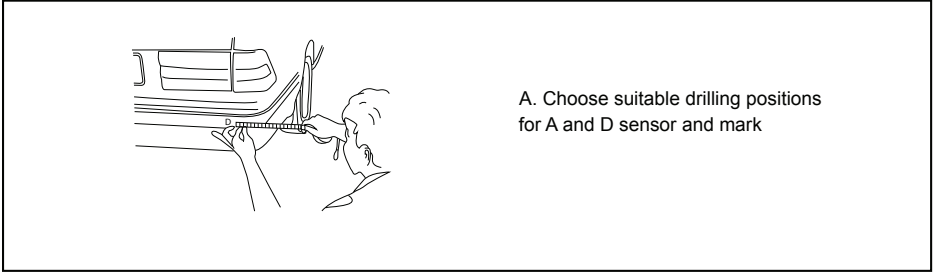

SELECT DRILLING POSITION FOR SENSOR B & C

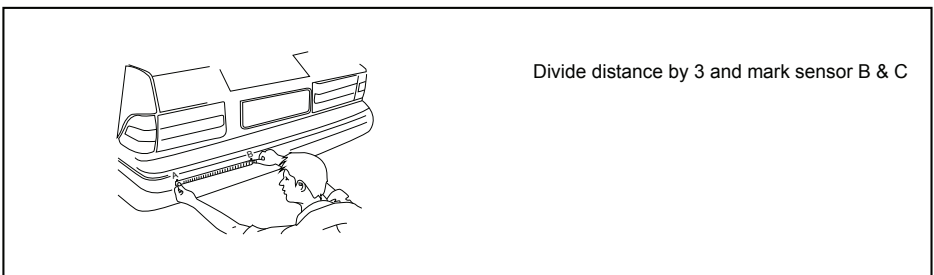
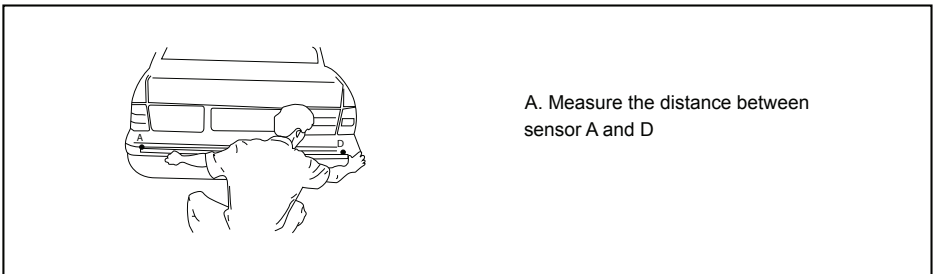

DRILLING

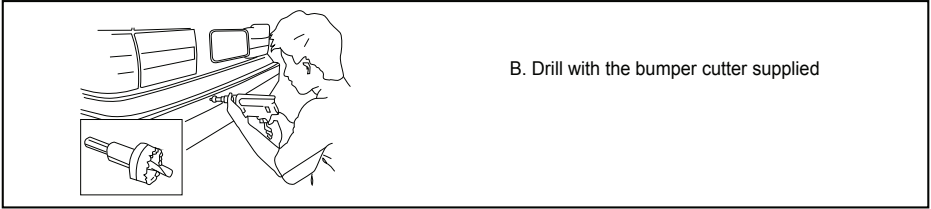
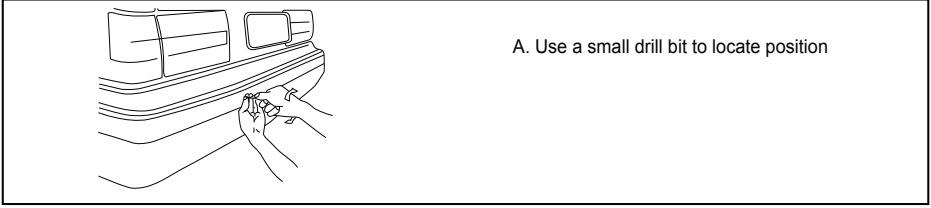

SENSOR INSTALLATION

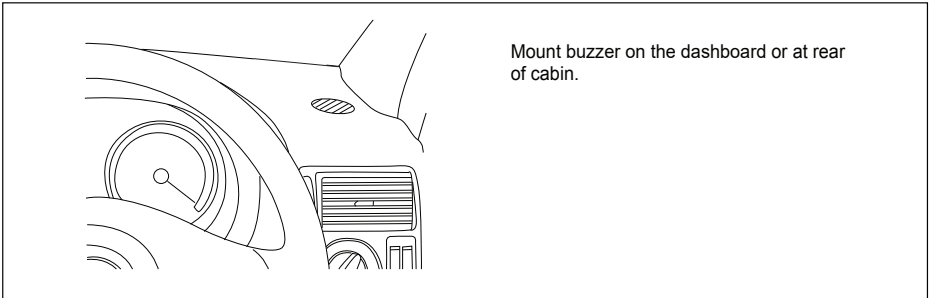
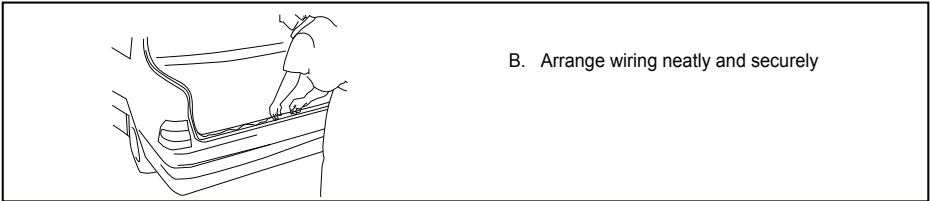
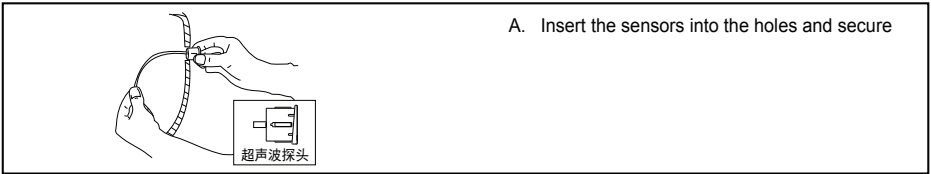

CONTROL BOX INSTALLTION

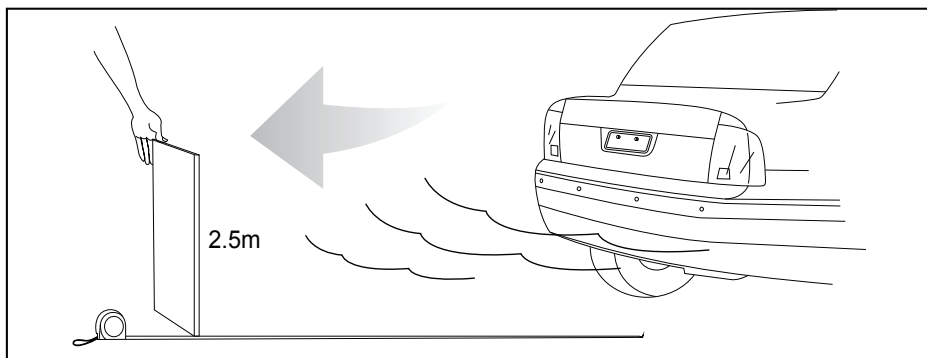
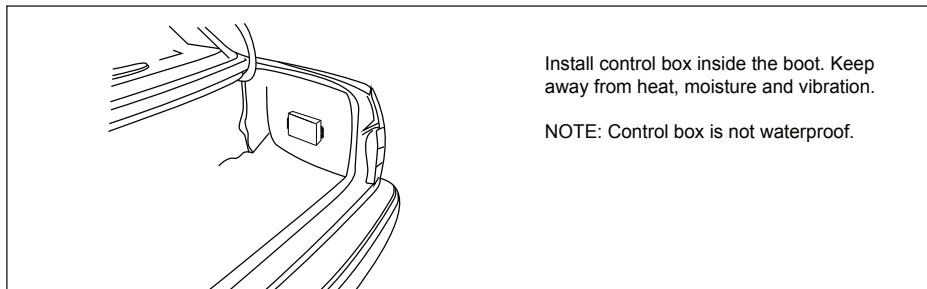

TROUBLE SHOOTING

Problem	Cause	Solution
The system is not activating.	The supply voltage is below <9 volts	Charge the vehicle's battery
	The fuse is blown	Replace the fuse with the same amperage fuse
	(Rear installation only) DIP switch 1 is set to ON	Set DIP switch 1 to the OFF position
The system is false alarming.	The sensitivity is set too high	Turn the sensitivity pot on the control module counter clockwise
	Either the tow-bar or another protruding object is being detected	Set DIP switch 2 to the ON position
	The sensors are angled too low or mounted too close to the ground	Change the angle of the sensors with angled spacers or relocate the sensors
The system is not detecting obstacles consistently.	The sensitivity is set too low	Turn the sensitivity pot on the control module clockwise
	The sensors are angled too high or mounted too high off the ground	Change the angle of the sensors with angled spacers or relocate the sensors

SPECIFICATIONS

GENERAL

- Rated Voltage: 12/24V DC
- Operating Range: 9-32V DC
- Operating Current: 20~150mA @ 12V

BUZZER

- Proximity Alert: Audible Tone
- Audible Buzzer: 70 ~110dB @ 10cm (Selectable Level)
- Cable Length: 8m (LED display)

CONTROL BOX

- Adjustments: DIP Switch 1 - Front or Rear Use
DIP Switch 2 - Rear Range Select / Tow Bar Adjustments
Front Setting: Speed Setting Adjustment
Front Setting: Auto On/Off with Brake
- Power Leads: 4.5m
- Dimensions: 100 x 54 x 24mm

SENSORS

- Sensor Type: Paintable ABS
- Sensor Size: 18mm
- Sensor Hole Cut-out: 18.3mm
- Sensor Cable Length: 3.5m
- Sensor Installation: Under Mount or In-Bumper Mount
Front: =400 ~ 500mm High
Rear: =500 ~ 600mm High
Front setting: 0.3 ~1.5m
- Detecting Distance: -30° to +85°C
- Working Temperature: IP68
- Water Resistance: 26W x 26H x 23.8Dmm
- Sensor Dimensions: 61W x 31H x 22.4Dmm
- Under Mount Dimensions:

INCLUDED

- 1x Control Box
- 4x Sensor
- 1x Buzzer
- 1 x Power cable
- 1x Drill
- 1x Manual
- 1x Accessories

NOTES

NOTES

NOTES

WARRANTY

Congratulations on your purchase. You're joining thousands of satisfied customers who enjoy & experience the benefits of the products we distribute. In the unlikely event that some technical difficulty arises with your purchase, be assured that we are most anxious to see that the problem is quickly rectified to your satisfaction. Please familiarise yourself with the following simple conditions of our warranty. This warranty covers faults through component failure or failure of the product to operate in accordance with published specifications. Product failure as a result of unreasonable environmental conditions, accident, misuse, improper installation, unauthorised repair, vehicle electrical or wiring faults or neglect etc, will not be covered by this warranty. Removal and installation costs, if any, would be paid by the owner as well as any freight or postage costs of transporting the product to AUTOBACS AUSTRALIA PTY LTD and shall not be liable or responsible for any loss of use of this product or any form of consequential loss.

CONSUMER WARRANTY

This product is warranted by AUTOBACS AUSTRALIA PTY LTD to be free from defects in materials and workmanship under **NORMAL USE** for a period of **TWENTY FOUR MONTHS** from the date of purchase.

WITHIN 30 DAYS OF PURCHASE DATE:

Please return the unit for replacement to our National Service Centre or the Retailer from where you made the purchase. All accessories must be included. Proof of purchase date **must** accompany the products.

AFTER 30 DAYS OF PURCHASE DATE:

Warranty repair and service is carried out by our National Service Centre. Repair and service will be carried out at no cost to the owner if proof of ownership and the date of purchase can be verified to the satisfaction of the authorised centre concerned with this repair. This proof should take the form of either:

- The warranty card accompanying this product, stamped and dated by the dealer.
- A Tax Invoice or Receipt showing full details of original vendor, purchaser, model number and serial number.

COMMERCIAL WARRANTY

A product used in or associated with a commercial application will carry a limited TWELVE MONTHS warranty. An abnormal commercial application is one where usage, dust, vibration, heat/cold and other environmental conditions exist at an extreme level.

Our goods come with guarantees that cannot be excluded under the Australian Consumer Law. You are entitled to a replacement or refund for a major failure and for compensation for any other reasonably foreseeable loss or damage. You are also entitled to have the goods repaired or replaced if the goods fail to be of acceptable quality and the failure does not amount to a major failure.

Purchaser's Name: _____

Purchaser's Address: _____

Model Number: _____ **Serial Number:** _____

Dealer Name: _____ **Date of Purchase:** / /

Dealer Address: _____

Invoice/Sales Docket no: _____

General Hints: To expedite service and prompt return of the equipment, please:

- Clearly describe the fault in detail
- Safely and securely pack the unit for transport
- Include your return address
- Provide proof of purchase date as outlined above

National Service Contacts:
AUTOBACS AUSTRALIA PTY LTD
Telephone: 1300 288 029
email: services@autobacs.com.au

