

# axis

JAPAN

日本の品質  
— JAPAN QUALITY —

## SPECIFICATIONS

- Image Sensor: 1/3" Sony CCD
- Auto Lens: f2.9mm
- Electronic Shutter: Auto
- Diagonal Viewing Angle: 120°
- Horizontal Viewing Angle: 90°
- Signal System: PAL
- Resolution: 700 TV Lines
- Sync System: Internal
- Orientation: Mirror Image
- Night Vision: Yes, 18 LED
- Illumination: 0 Lux with IR on
- Ingress Protection: IP69K
- Microphone: Yes
- Operating Temperature: -20°C ~ 70°C
- Dimensions: 70W x 45H x 60D mm  
(Excl Bracket)
- Connection: Terminated 4-Pin Male
- Power Supply: 12V DC (From Monitor)
- Extension Cable: 15m 4 Pin Male to 4 Pin Female

### INCLUDES

- 15m 4 Pin (Male) to 4 Pin (Female) Extension Cable
- Mounting Bracket
- Sunvisor

CC08W  
**Heavy Duty  
CCD Camera**



# WIRING DIAGRAM

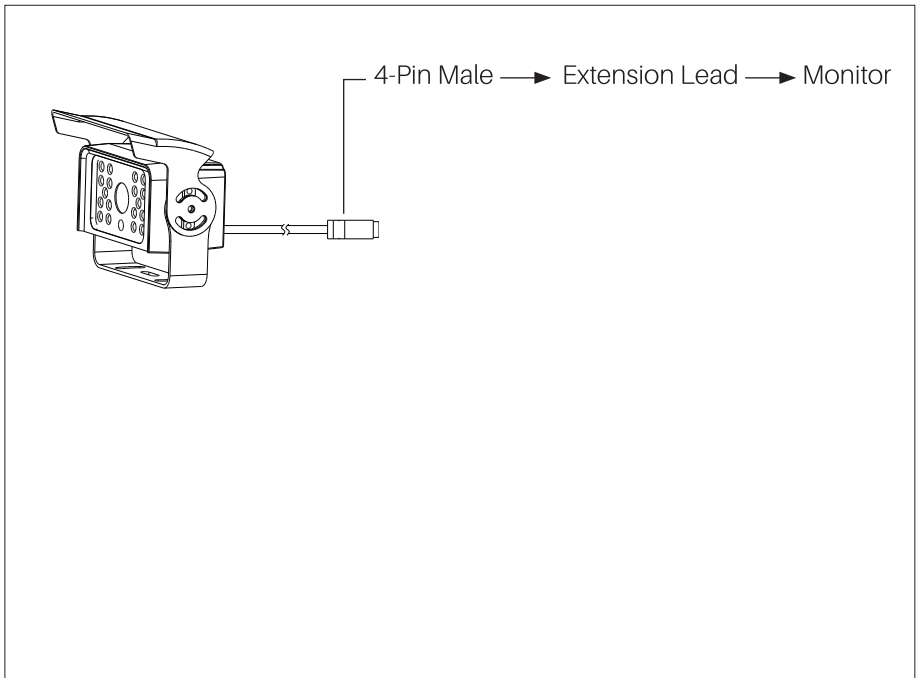
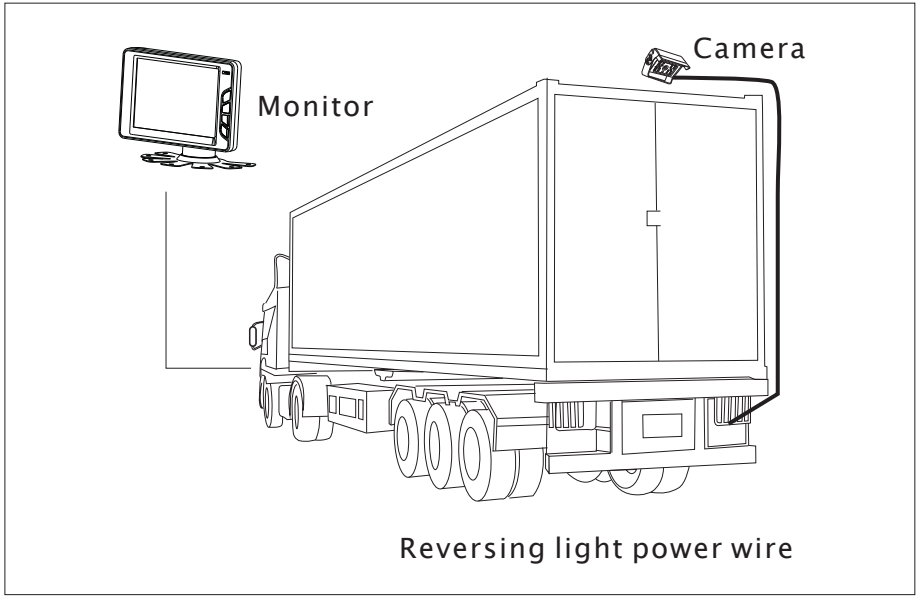

# CAMERA INSTALLATION

## Suspension installation

It can be mounted on the vehicle's top and its viewing angle is adjustable. Use the enclosed screws to fasten the camera.

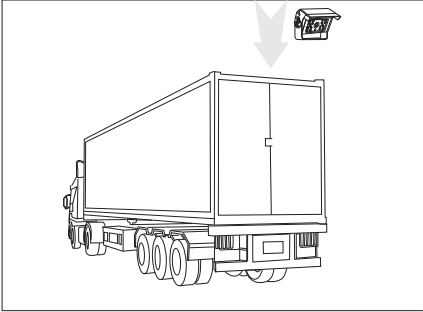

1. Vertical Suspension

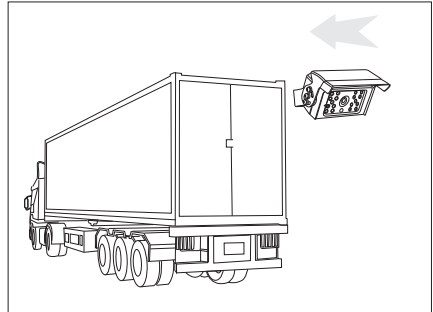

2. Side Suspension

## How to adjust the camera mounting bracket

Use slotted screwdriver to loosen the screws on the side of the camera, adjust the bracket in the right position, and then tighten the screws.

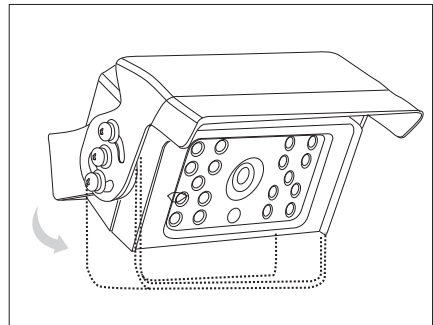
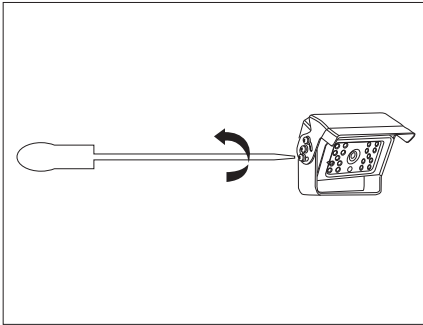

### Note:

Be sure to adjust the camera into the best viewing angle as above.

This system is a reversing aid and the manufacturer will take no responsibility for any accident after the kit is installed.

# WARRANTY

Congratulations on your purchase of a quality **axis** Mobile Safety System! You're joining thousands of satisfied customers who enjoy & experience the benefits of the products we distribute. In the unlikely event that some technical difficulty arises with your purchase, be assured that we are most anxious to see that the problem is quickly rectified to your satisfaction. Please familiarise yourself with the following simple conditions of our warranty. This warranty covers faults through component failure or failure of the product to operate in accordance with published specifications. Product failure as a result of unreasonable environmental conditions, accident, misuse, improper installation, unauthorised repair, vehicle electrical or wiring faults or neglect etc, will not be covered by this warranty. Removal and installation costs, if any, would be paid by the owner as well as any freight or postage costs of transporting the product to AUTOBACS AUSTRALIA and shall not be liable or responsible for any loss of use of this product or any form of consequential loss.

## CONSUMER WARRANTY

This product is warranted by AUTOBACS AUSTRALIA PTY LTD to be free from defects in materials and workmanship under **NORMAL USE** for a period of **TWENTY FOUR MONTHS** from the date of purchase.

### WITHIN 30 DAYS OF PURCHASE DATE:

Please return the unit for replacement to our National Service Centre or the Retailer from where you made the purchase. All accessories must be included. Proof of purchase date **must** accompany the products.

### AFTER 30 DAYS OF PURCHASE DATE:

Warranty repair and service is carried out by our National Service Centre. Repair and service will be carried out at no cost to the owner if proof of ownership and the date of purchase can be verified to the satisfaction of the authorised centre concerned with this repair. This proof should take the form of either:

- a) The warranty card accompanying this product, stamped and dated by the dealer.
- b) A Tax Invoice or Receipt showing full details of original vendor, purchaser, model number and serial number.

## COMMERCIAL WARRANTY

A product used in or associated with a commercial application will carry a limited SIX MONTH warranty. An abnormal commercial application is one where usage, dust, vibration, heat/cold and other environmental conditions exist at an extreme level.

Our goods come with guarantees that cannot be excluded under the Australian Consumer Law. You are entitled to a replacement or refund for a major failure and for compensation for any other reasonably foreseeable loss or damage. You are also entitled to have the goods repaired or replaced if the goods fail to be of acceptable quality and the failure does not amount to a major failure.

Please complete details below in the event of warranty service being required.

<b>Purchaser's Name:</b> _____	
<b>Purchaser's Address:</b> _____ _____	
<b>Model Number:</b> <b>CC08W</b>	<b>Serial Number:</b> _____
<b>Dealer Name:</b> _____	<b>Date of Purchase:</b> /     /
<b>Dealer Address:</b> _____	
<b>Invoice/Sales Docket no:</b> _____	
General Hints: To expedite service and prompt return of the equipment, please:	
a) Clearly describe the fault in detail	b) Safely and securely pack the unit for transport
c) Include your return address	d) Provide proof of purchase date as outlined above

**National Service Contacts:**  
**AUTOBACS AUSTRALIA PTY LTD**  
Telephone: 1300 288 029  
email: services@autobacs.com.au

