



FUJI SERIES

1/3" Full HD Dome Camera



FHD767

HD Wiring configuration:

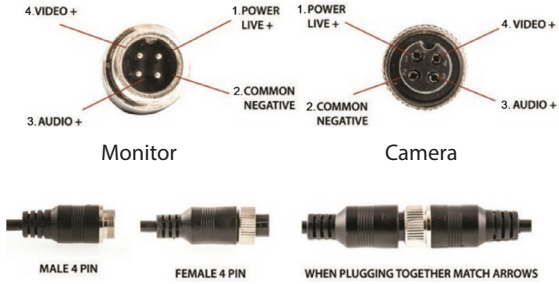

FHD767 Camera

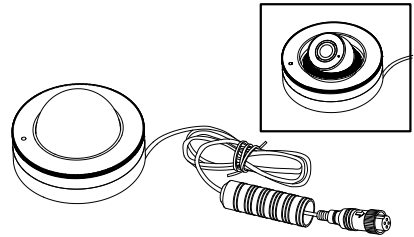

Note: Compatible with HD monitors only

Assembly

Camera

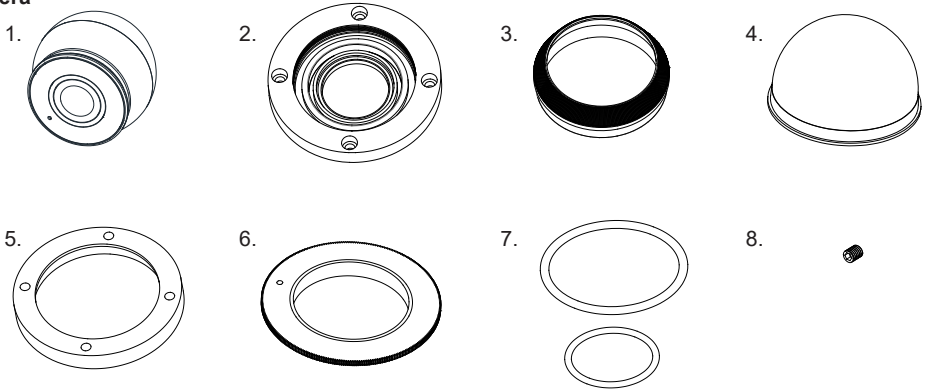

Accessories

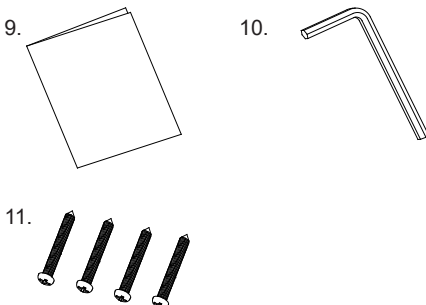

1. Camera	x1
2. Swinging base	x1
3. Outer ring for camera	x1
4. Transparent cover	x1
5. Washer	x1
6. Top cover	x1
7. O-Rings	x1
8. Hexagon socket set screws	x1
9. Instruction Manual	x1
10. Allen Key	x1
11. Screws	x1

Installation

1. Fix the base to an appropriate location. (Pic 1)

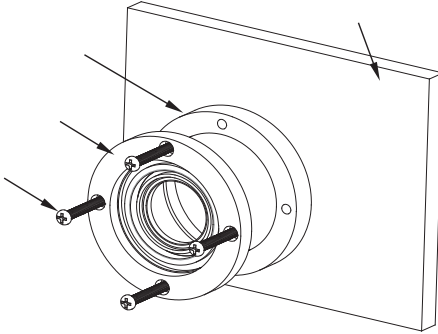

(Pic 1)

2. Tighten outer ring and fix the camera. (Pic 2)

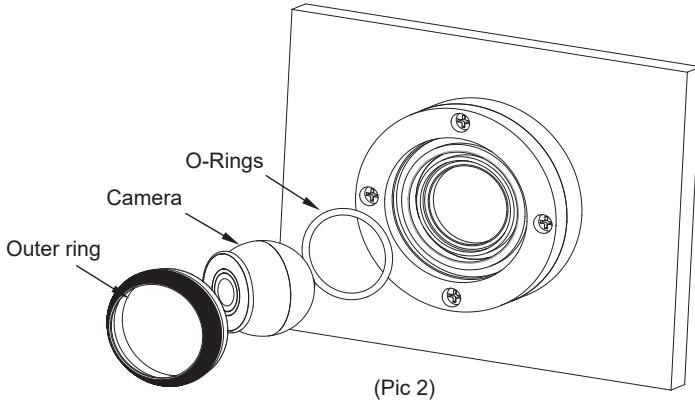

(Pic 2)

3. Adjust the camera to the desired viewing angle and tighten top cover. (Pic 3)

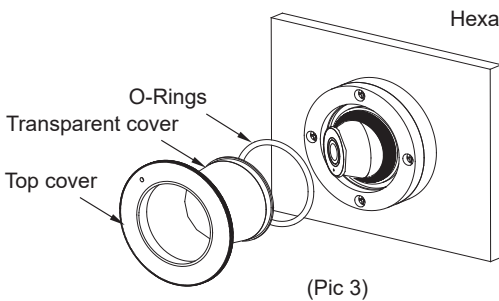

(Pic 3)

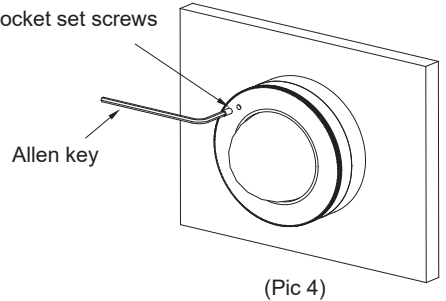

(Pic 4)

4. Lock the hexagon socket set screws using the allen key. (Pic 4)

SPECIFICATIONS

CAMERA

- Image Device: 1/3" Sony CMOS
- Diagonal Viewing Angle: 150°
- Signal System: PAL
- Effective Pixels: 1920H x 1080V
- Resolution: 1080p
- Sync System: Internal
- Orientation: Mirror View
- Ingress Protection: IP69K
- Connection: Terminated to 4 Pin Female
- Integrated Microphone: No
- Operating Temp: -20 to 70°C
- Power Consumption: 70mA±10
- Dimensions: Ø76 x 44H mm
- Connection: Terminated 4-Pin Female
- Power Supply: 12V DC

INCLUDED:

- Installation Manual
- Mounting Bracket

NOTES

NOTES

NOTES

WARRANTY

Congratulations on your purchase of a quality Mobile Safety System! You're joining thousands of satisfied customers who enjoy & experience the benefits of the products we distribute. In the unlikely event that some technical difficulty arises with your purchase, be assured that we are most anxious to see that the problem is quickly rectified to your satisfaction. Please familiarise yourself with the following simple conditions of our warranty. This warranty covers faults through component failure or failure of the product to operate in accordance with published specifications. Product failure as a result of unreasonable environmental conditions, accident, misuse, improper installation, unauthorised repair, vehicle electrical or wiring faults or neglect etc, will not be covered by this warranty. Removal and installation costs, if any, would be paid by the owner as well as any freight or postage costs of transporting the product to AUTOBACS AUSTRALIA PTY LTD and shall not be liable or responsible for any loss of use of this product or any form of consequential loss.

CONSUMER WARRANTY

This product is warranted by AUTOBACS AUSTRALIA PTY LTD to be free from defects in materials and workmanship under **NORMAL USE** for a period of **THIRTY SIX MONTHS** from the date of purchase.

WITHIN 30 DAYS OF PURCHASE DATE:

Please return the unit for replacement to our National Service Centre or the Retailer from where you made the purchase. All accessories must be included. Proof of purchase date **must** accompany the products.

AFTER 30 DAYS OF PURCHASE DATE:

Warranty repair and service is carried out by our National Service Centre. Repair and service will be carried out at no cost to the owner if proof of ownership and the date of purchase can be verified to the satisfaction of the authorised centre concerned with this repair. This proof should take the form of either:

- a) The warranty card accompanying this product, stamped and dated by the dealer.
- b) A Tax Invoice or Receipt showing full details of original vendor, purchaser, model number and serial number.

COMMERCIAL WARRANTY

A product used in or associated with a commercial application will carry a limited TWELVE MONTHS warranty. An abnormal commercial application is one where usage, dust, vibration, heat/cold and other environmental conditions exist at an extreme level.

Our goods come with guarantees that cannot be excluded under the Australian Consumer Law. You are entitled to a replacement or refund for a major failure and for compensation for any other reasonably foreseeable loss or damage. You are also entitled to have the goods repaired or replaced if the goods fail to be of acceptable quality and the failure does not amount to a major failure.

Purchaser's Name: _____

Purchaser's Address: _____

Model Number: _____ **Serial Number:** _____

Dealer Name: _____ **Date of Purchase:** / /

Dealer Address: _____

Invoice/Sales Docket no: _____

General Hints: To expedite service and prompt return of the equipment, please:

- a) Clearly describe the fault in detail
- b) Safely and securely pack the unit for transport
- c) Include your return address
- d) Provide proof of purchase date as outlined above

National Service Contacts:

AUTOBACS AUSTRALIA PTY LTD

Telephone: 1300 288 029 Fax: (02) 9636 1204

email: services@audioxtra.com.au

