

Uniden®

FP1200

LCD Display

Caller ID

Speaker Phone

*For more exciting new products please visit our
website:*

Australia: www.uniden.com.au

New Zealand: www.uniden.co.nz

OWNER'S MANUAL

SAFETY INSTRUCTIONS

To reduce the risk of fire, electrical shock, and injury, please follow these basic safety precautions before you use this equipment.

1. Carefully read the instructions in this manual.
2. Follow all warnings and instructions marked on the unit.
3. When cleaning, unplug the telephone jack from the wall outlet. Use a damp cloth. **DO NOT** use liquid or aerosol cleaners.
4. Do not use this equipment near water eg, near a kitchen sink, bath-Tub, washbowl, laundry tub, swimming pool or in a wet basement.
5. Install in a protected location. Ensure all lines and cords are away from foot traffic. **DO NOT** place objects on the line cord that may cause damage or abrasion.
6. Avoid spilling any liquid on the unit. This may cause internal shorting, fire or shock and is not covered under your warranty.
7. Do not overload wall outlets and extension cords as this can result in the risk of fire or electrical shock.
8. Never push objects of any kind into this telephone as they can touch dangerous voltage points or short out parts that could result in a risk of fire or electrical shock.
9. Take the phone to a qualified technician when it requires repair work or service. To reduce the risk of electrical shock, do not disassemble the telephone. Opening or removing covers can expose you to dangerous voltages or other risks. Incorrect re-assembly can cause electrical shock during subsequent use.
10. Avoid using the telephone during an electrical storm. There can be a slight risk of electrical shock from lightning.
11. **DO NOT** use the telephone to report a gas leak, if in the vicinity of the leak.
12. Unplug this telephone from the wall outlet and refer servicing to qualified service personnel under the following conditions:
 - If liquid is spilled into the unit.
 - If the unit is exposed to rain or water.
 - If the unit does not operate normally by following the operating Instructions.
 - If the unit is dropped or the casing is damaged.
 - If the unit exhibits a distinct change in performance.

TABLE OF CONTENTS

SAFETY INSTRUCTIONS	3
TABLE OF CONTENTS	4
INTRODUCTION	5
Feature List	5
What's in the Box?	5
Optional Backup Battery Installation	6
Connecting Line Cords	6
Connecting the Wall Mount Bracket	7
Mounting the Phone Directly on the Wall	7
LOCATION OF CONTROLS	8
KEY FUNCTIONS	10
Ringer Volume Switch	10
Ringer Pitch Switch	10
Speaker Volume Switch	10
REDIAL Function	10
SPEAKER Function	10
PAUSE Function	10
MUTE Button	11
FLASH Button	11
STORE Button	11
PHONEBOOK Button	11
SPEED DIAL NUMBERS	12
PHONEBOOK	13
SETTING THE DATE & TIME	14
CALLER ID	15
REVIEWING DISPLAY MESSAGES	15
CALLER ID OPERATION	17
TROUBLESHOOTING	20
ONE YEAR LIMITED WARRANTY	21

INTRODUCTION

FEATURE LIST

- **Caller ID***
- **66 Caller ID memory**
- **10 outgoing calls number**
- **70 Phonebook memory**
- **6 One-Touch Memories**
- **Speakerphone**
- **Adjustable Ringer Control**
- **Large LCD Display**
- **Backlit LCD and keypad**
- **Call back function**
- **Real Time Clock (Time Set)**
- **Insert 0 ON/OFF**
- **Message Waiting Function**
- **Last Number Redial**
- **Flash, Pause, Mute**
- **Timer**

*** Caller ID, Caller ID features and Message Waiting work only if you subscribe to the services provided by your local telephone company. There is usually a fee for this services.**

WHAT'S IN THE BOX?

Make sure your corded phone's packaging includes the following items:

- Telephone Base
- Handset & curly cord
- AC adaptor
- Wall Mount bracket
- Telephone line cord



If any items are missing or damaged, contact your place of purchase immediately. Never use damaged products!

OPTIONAL BACKUP BATTERY INSTALLATION

Batteries may be used instead of the supplied AC Adaptor. (The LCD and keypad backlight is available only when the AC adaptor is connected.)

1. Remove the battery compartment cover.
2. Fit 3 x AAA alkaline batteries.
3. Replace the cover.

Based on ½ hour use per day, good alkaline batteries should last 2-3 months.



If using the AC Adaptor, Batteries are not required for normal operation.



Always ensure telephone cord and AC adaptor is disconnected before opening the battery compartment door and installing batteries.
Caution, risk of explosion if battery is replaced by an incorrect type. Dispose of used batteries according to the instructions.

CONNECTING LINE CORDS

Plug one end of the supplied modular cord into the line jack. Then plug the other end into telephone wall line jack.

CONNECTING THE WALL MOUNT BRACKET

To mount the telephone on a wall, first slot the Wall Mount Bracket into the bottom two Mounting Bracket Location Slots at the back of the base. Check the wall mount bracket is the correct orientation.



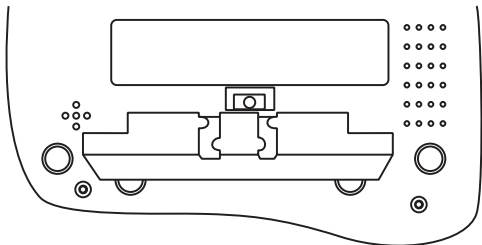

On the base front, slide the handset hook out of the slot. Rotate hook 180 degrees and flip it from front to back. Slide it back into the slot. It should extend slightly; this extension fits into a slot on the handset.

MOUNTING THE PHONE DIRECTLY ON THE WALL

Before doing this, consider the following:

- Avoid electrical cables, pipes, or other items behind the mounting location that could cause a hazard when inserting screws into the wall.
- Mount your phone within distance of a working phone jack.
- Make sure the wall material is capable of supporting the weight of the base and handset.
- Use screws with anchoring devices suitable for the wall material where the base unit will be placed.
- Be sure the wall is capable of supporting the weight of the phone, and use the proper type of anchoring device for the wall material.
- Insert two #10 screws (minimum length of 35mm, not supplied) into the wall, 78mm horizontally apart.
- Leave the screw heads 3mm away from the wall to allow room for mounting the phone.
- Align the mounting slots over the screws and slide the base down into place.

LOCATION OF CONTROLS

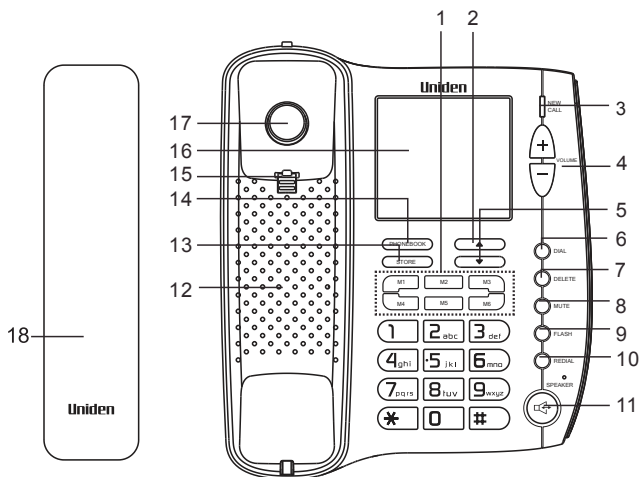



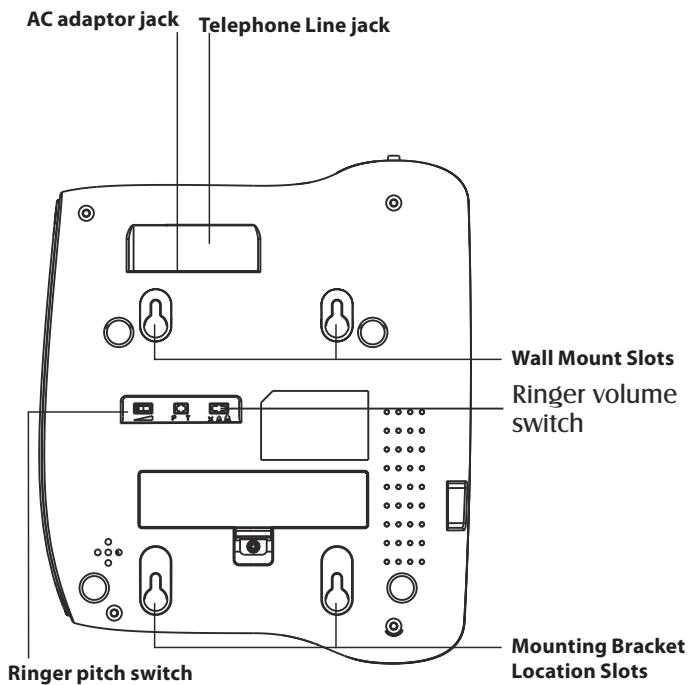



- | | |
|----------------------------------|--|
| 1. Memory buttons (M1~M6) | 11.  Speaker button |
| 2. ▲ button | 12. Speaker |
| 3. New call indicator | 13. STORE button |
| 4. Volume +/- buttons | 14. PHONEBOOK button |
| 5. ▼ button | 15. Handset Hook |
| 6. DIAL button | 16. LCD display |
| 7. DELETE button | 17. Hook switch |
| 8. MUTE button | 18. Handset |
| 9. FLASH button | |
| 10. REDIAL / PAUSE button | |



KEY FUNCTIONS

Ringer Volume Switch

Set the ringer volume switch to the desired position ( /  / ). To have the maximum ringer volume, move the ring volume switch to the  position. To have a low ringer volume, move the ringer volume switch to the  position. If you would prefer the ringer not to disturb you, move the switch to the  position.

Ringer Pitch Switch

Set the ring pitch switch to the desired level (Hi or Lo). The switch is located at the back of the unit.

Speaker Volume Switch

During the conversation, you can press **VOL+** or **VOL-** to adjust the speaker volume (4 levels for selection).

REDIAL Function

Lift the handset or press , then press **REDIAL** to redial the last dialled number.

SPEAKER Button

To switch your call to speakerphone, press  and hang up the handset. To switch back, simply pick up the handset and speak as normal. In speaker mode, you can make or answer a call.

PAUSE Function

To insert a temporary pause, press **REDIAL** during a dialling sequence. For example, in some cases when dialling an international number you need to place a pause between the clusters of numbers to allow the telephone company, relaying the call, time to process it. The number 011-886-22-795-1234 would need to be dialled; 011 PAUSE(REDIAL) 886 PAUSE(REDIAL) 22 PAUSE(REDIAL) 795 PAUSE(REDIAL) 1234.

MUTE button

Press **MUTE** to turn off the telephone's microphone so that the other party cannot hear you, but you can hear them. Press **MUTE** again to restore connection to the microphone so the other party can hear you again. The LCD will display " **MUTE**" while the function is active.'

FLASH button

If the Call Waiting tone sounds while you are on a call;
Australia: Press **FLASH** and then **(2)** to switch between callers.
New Zealand: Press **FLASH** to switch between callers.

STORE Button

For storing One-Touch speed dial numbers (see page 12).

PHONEBOOK Button

To storing and accessing the Phonebook (see page 13).

SPEED DIAL NUMBERS

Storing One Touch Speed Dial Numbers

You can store a number to the one-touch memory in two ways:

A. In the on-hook state;

1. Press and hold **STORE**, the LCD shows -->.
2. Enter the telephone number you want to store.
3. Press **STORE** again, the LCD shows -->?.
4. Press the desired location button (**M1~M6**) and the LCD shows **SAVE OK**.

or

B. First enter the number you want to store then press and hold the (**M1~M6**) button until the LCD shows **SAVE OK**.

To dial a number from one-touch memory

Lift the handset or press the  button then press the location button (**M1~M6**) to dial out the matching number.

To review the number in one-touch memory

In the on-hook state, press the location button (**M1~M6**), the matching number will be displayed on the LCD.

PHONEBOOK

To store number to phonebook

1. In the standby mode press and hold the **PHONEBOOK**.
2. Enter the telephone number by numeric keypad. Press the **DELETE** button to delete the previous digit if necessary. The maximum number of digits to be entered is **20**. If the number exceeds , the LCD will show **TOO LONG** and the exceeding digits will not be stored.
3. After the number setting, press **PHONEBOOK** to enter the name setting (up to 16 characters), press the appropriate keypad to get the following characters, If the next character is on the same button as the previous one, you will first need to press **DIAL** before the entering. Press **DELETE** to delete the previous character if necessary.

Key	Characters	Key	Characters
1	1 . , ? ! - ' ()	6	M N O m n o 6 Ö Ø Ñ
2	A B C a b c 2 Å Ä Æ	7	P Q R S p q r s 7
3	D E F d e f 3	8	T U V t u v 8 Ü
4	G H I g h i 4	9	W X Y Z w x y z 9
5	J K L j k l 5	0	0 + & @ / \$ %

4. When the setting is completed, press **PHONEBOOK** to store the records and meanwhile enter the next number presetting.

To review number/name in phonebook

1. Press **PHONEBOOK** in the standby mode, then use ▲ or ▼ to review. You can also quickly review the call by the first letter of the name, when press the first letter of the name, the LCD will display the matching name(s), then use ▲ or ▼ to get the right one.
2. In the on-hook state, press **sequence of the number** and then # to review. e.g.: If you want to review the seventh number, just press **7** and then #, the LCD will show the seventh number and name. In this state, you can continue review the other numbers by pressing ▲ or ▼.



If the number is more than 13 digits, an arrow will show on the bottom right of LCD, press ▲ or ▼ to review the other digits, press ▲ or ▼ again to review the next call.

To speed dial a number from phonebook

During the reviewing process, use ▲ or ▼ to select the desired number. When the number shows on the LCD, pick up the handset or press the  button to dial it out.

To Edit a Phonebook Entry

During the reviewing process, use ▲ or ▼ to select the number you want. When it shows on the LCD, press and hold **PHONEBOOK** for about 3 seconds. The first character of the name will flash to indicate that you can modify the name.

To Delete a Phonebook Entry

During the review process select the entry you wish to delete. Press **DELETE** once, the LCD shows **DELETE?**
Press **DELETE** again to delete the entry.

SETTING THE DATE & TIME

If you subscribe to a Caller ID Service, your time and date will automatically be set for you when you receive your first call to this unit.

1. Press and hold **FLASH** until the LCD shows **SET TIME**, use ▲ or ▼ to select the correct number.
2. Press **DIAL** to confirm and move to the next digit.
3. Press **DELETE** to exit.

CALLER ID

A caller ID record consists of the following information:

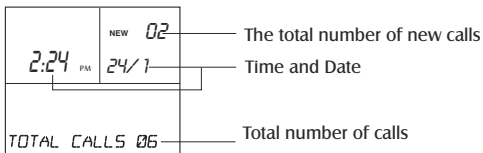

For Caller ID features to operate you must first subscribe to this service through your local telephone company.

REVIEWING DISPLAY MESSAGES

MESSAGE WAITING - If you have voicemail service from your telephone company and a recorded message is left, the screen will display **MESSAGE WAITING**, ☒ will also appear on the left side of the LCD. The icon will remain until you have reviewed your voice mail and the **MESSAGE WAITING** will be saved as a call.

☒	CALL # NEW 02
2:24 PM	24/1
MESSAGE WAITING	



For Message Waiting features to operate you must first subscribe to this service through your local telephone company.

NO CALLS - When all calls have been deleted. The display will show **NO CALL**

	NEW 02
2:24 PM	24/1
TOTAL CALLS 00	

TOTAL & NEW CALLS - This shows you the total and new calls to be reviewed. In this example, you have 6 calls in total which includes 2 new calls.

2:24 PM	NEW 02 24/1
TOTAL CALLS 06	

PRIVATE - If the caller has exercised the option to prevent his name and number from being sent, **PRIVATE** will be shown on the screen.

2:24 PM	CALL # NEW 02 24/1
PRIVATE	

REPEAT CALLS - If a call comes repeatedly, the display will show **REPEAT** icon in the upper right corner of the LCD.

2:24 PM	CALL # REPEAT 02 24/1
230	

END OF LIST - This message is displayed when reaching the top (end) of the call history list by using the ▲ or ▼. If there is no call, then LCD shows **NO CALL**.

2:24 PM	24/1
END OF LIST	

OUT OF AREA - This message will display when some one calls from an area where the telephone company is not offering the caller identification services or is not yet providing name and number delivery to your area.

2:24 PM	CALL # NEW 02 24/1
OUT OF AREA	

CALLER ID OPERATION

Subscription to Caller ID service from your local phone company is required before the first use.

New call indicator

The red New call indicator will flash to indicate that you have new calls and it will flash until all the new calls have been reviewed.

Insert 0 function

To correctly display and dial Call ID numbers, you may need to insert a digit at the beginning of your telephone number. (eg: in New Zealand, Telecom requires a '0' to be inserted.)

New Zealand:

If you subscribe to Telecom New Zealand, this code has already been set for you to 'ON'. If you subscribe to another telephone company, please set the insert 0 to "ON".

If this phone is used with a business PABX - consult the PABX manufacturer for the correct setting.

Australia:

For private household telephone lines, set insert 0 to **OFF**.

If this phone is used with a business PABX - consult the PABX manufacturer for the correct setting.

While the handset is on the base:

1. Press **DELETE** twice quickly. **INSERT 0 OFF** or **INSERT 0 ON** will be displayed.
2. Use ▲ and ▼ to choose on or off.
3. Press **DIAL** to store.

Review Your Call Records

Press ▲ or ▼ to scroll through the caller list. If the call is more than 13 digits, an arrow will show on the bottom right of LCD, press ▲ or ▼ once to review the other digits, press ▲ or ▼ again to review next call. At the end of the call record list, you will see the message. Press ▲ or ▼ to continue.

Using the Call back feature



If the number is blocked or is unavailable, it cannot be called back.)

A. Call back the dialled number: The unit can store up to 10 dialled numbers.

1. In the on-hook state, press **DIAL** once, the last dialled number will show on the LCD, then use ▲ or ▼ to select the number that you want to dial out.
2. Pick up the handset or press , the phone number can be dialled out automatically.



To call back the last dialled number, you can lift the handset to get a dial tone, then press REDIAL.

B. Call back the called number: The unit can store minimum 66 called numbers.

1. Lift the handset or press  to get a dial tone.
2. Select the caller that you want to call back by pressing ▲ or ▼.
3. Press **DIAL** to automatically dial the phone number shown on the LCD.

Or

4. Select the caller that you want to call back by pressing ▲ or ▼ in the on hook state.
5. Pick up the handset or press .
6. Press the **DIAL** to automatically dial the phone number.

Save the Caller ID Records

Your phone stores minimum 66 Call Records before the memory becomes full. When the next call comes in, the oldest record automatically drops off and makes room for the new call Record.

Delete single or all record number(s)

In the on-hook state, press ▲ or ▼ to select the number which you want to remove, press **DELETE**, the LCD will show **DEL?** and then press **DELETE** again to remove this number, press any other button to exit. If you press and hold **DELETE** for about 6 seconds, the LCD will show **ALL DEL?**. Press the **DELETE** to remove all numbers and the LCD will show **NO CALL**.

TROUBLESHOOTING

If you are having problems with your phone, please check below for helpful hints:

BLANK OR FAINT SCREEN CALLER ID WILL NOT WORK PROPERLY PHONE WILL NOT RING	<ul style="list-style-type: none">- Check the line cord. Connect Telephone Cord.- Call your telephone company to verify that your Caller ID services are active.- You may have too many communication devices hooked to a single line. A communication device can be a phone, modem, or facsimile (FAX) machine. Contact your telephone company for help in calculating the limit for your residence or business line.
NO DIAL TONE	<ul style="list-style-type: none">- Verify that the LINE CORD is plugged in correctly.- Verify that the Line Cord connection is correct and tightly secured.
NO DATA SENT	<ul style="list-style-type: none">- Call your telephone company to verify that your caller ID services are active.- If you have an answering machine connected to this Phone, ensure that your answering machine is set to answer after at least two rings.- You answer the call before two rings.- Contact your telephone company if the problem continues for more than 24 hours. The telephone company may be experiencing temporary line
NO RESPONSE ON LCD DISPLAY	<ul style="list-style-type: none">- If you have experienced a power failure, the batteries for memory back up could become weak or dead. If the power is restored and the display screen does not respond then you must replace the batteries with new.

ONE-YEAR LIMITED WARRANTY

UNIDEN FP1200

IMPORTANT Satisfactory evidence of the original purchase is required for warranty service

Please refer to our Uniden website for any details or warranty durations offered in addition to those contained below.

Warrantor

The warrantor is either Uniden Australia Pty Limited ABN 58 001 865 498 ("Uniden Aust") or Uniden New Zealand Limited ("Uniden NZ") as the case may be.

Terms of Warranty

Uniden Aust/NZ warrants to the original retail purchaser only that the FP1200 ("the Product"), will be free from defects in materials and craftsmanship for the duration of the warranty period, subject to the limitations and exclusions set out below.

Warranty Period

This warranty to the original retail purchaser is only valid in the original country of purchase for a Product first purchased either in Australia or New Zealand and will expire one (1) year from the date of the original retail sale.

If a warranty claim is made, this warranty will not apply if the Product is found by Uniden to be:

- (A) Damaged or not maintained in a reasonable manner or as recommended in the relevant Uniden Owner's Manual;
- (B) Modified, altered or used as part of any conversion kits, subassemblies or any configurations not sold by Uniden Aust or Uniden NZ;
- (C) Improperly installed contrary to instructions contained in the relevant Owner's Manual
- (D) Repaired by someone other than an authorized Uniden Repair Agent in relation to a defect or malfunction covered by this warranty; or
- (E) Used in conjunction with any equipment, parts or a system not manufactured by Uniden.

Parts Covered

This warranty covers the Product and included accessories.

User-generated Data

This warranty does not cover any claimed loss of or damage to user-generated data (including but without limitation phone numbers, addresses and images) that may be stored on your Product.

Statement of Remedy

If the Product is found not to conform to this warranty as stated above, the Warrantor, at its discretion, will either repair the defect or replace the Product

without any charge for parts or service. This warranty does not include any reimbursement or payment of any consequential damages claimed to arise from a Product's failure to comply with the warranty.

Our goods come with guarantees that cannot be excluded under the Australian Consumer Law. You are entitled to a replacement or refund for a major failure and for compensation for any other reasonably foreseeable loss or damage. You are also entitled to have the goods repaired or replaced if the goods fail to be of acceptable quality and the failure does not amount to a major failure.

This warranty is in addition to and sits alongside your rights under either the COMPETITION AND CONSUMER ACT 2010 (Australia) or the CONSUMER GUARANTEES ACT (New Zealand) as the case may be, none of which can be excluded.

Procedure for Obtaining Warranty Service

Depending on the country in which the Product was first purchased, if you believe that your Product does not conform with this warranty, you should deliver the Product, together with satisfactory evidence of your original purchase (such as a legible copy of the sales docket) to Uniden at the addresses shown below. You should contact Uniden regarding any compensation that may be payable for your expenses incurred in making a warranty claim. Prior to delivery, we recommend that you make a backup copy of any phone numbers, images or other data stored on your Product, in case it is lost or damaged during warranty service.

UNIDEN AUSTRALIA PTY LTD

Service Division

345 Princes Highway,

Rockdale, NSW 2216

Phone number: 1300 366 895

Email address: custservice@uniden.com.au

UNIDEN NEW ZEALAND LTD

Service Division

150 Harris Road, East Tamaki

Auckland 2013

Phone number: (09) 273 8377

Email address: service@uniden.co.nz

Uniden®

©2011 Uniden Australia Pty Ltd/Uniden New Zealand Limited
Printed in PRC